



NARRATOR'S PRESENTATION GUIDE
FOR

**" THE TRACTOR TRANSMISSION
OF TOMORROW "**

AN EDUCATIONAL FILM ON
THE WORKING PRINCIPLE OF THE

IH "AGRIOMATIC" 8 SPEED TRANSMISSION

PREPARED BY
MERCHANDISING SERVICES DEPARTMENT
INTERNATIONAL HARVESTER COMPANY M. B. H.
NEUSS, RHINE, GERMANY

INTRODUCTION

This presentation guide and the strip film developed for use with it, have been produced to assist our sales force in the field, and to show to prospective buyers of tractors fitted with the "Agriomatic" 8-speed transmission.

Every effort has been made to keep both the individual film frames and the script as simple as possible in order that the principle of the "Agriomatic" may be easily understood.

It is suggested that such further technical matter as is required in subsequent "question and answers" sessions, be gleaned from the "Instruction Pamphlet and Parts List of the "Agriomatic" 8-speed Tractor Transmission." (No. 3,000,002 RI.)

In order to illustrate the principle of a change speed transmission, the first part of the narrator's guide and strip film is devoted to an explanation of a simple two-speed transmission. This has been done to enable less technically versed persons to understand more easily how a multiple speed transmission functions.

Much depends on the manner of presentation, and it is suggested that the contents of this guide be studied closely before making a presentation in order that your efforts may be as effective as possible.

More effective presentation can be made if the narrator faces his audience. The guide should be placed in a convenient position with a shaded light to facilitate reading. Use of a pointer to draw attention to various points during the presentation is recommended, and a second person armed with a copy of the script should operate the projector and trip the frames at the right moment.

It is hoped that the fullest use will be made of both the guide and the strip film — where no projector is available the presentation guide will serve as a useful training aid — and that they will enable everybody to know the "Agriomatic" better and to discuss it with confidence.

MERCHANDISING SERVICES DEPARTMENT
Neuss, Rhine, Germany.

INTERNATIONAL HARVESTER
COMPANY M.B.H.
NEUSS

Presents

"THE TRACTOR
TRANSMISSION
OF TOMORROW"

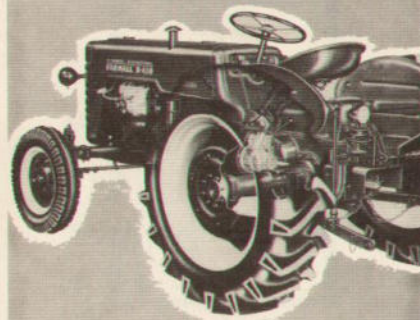

INTERNATIONAL HARVESTER COMPANY M.B.H.,
NEUSS, PRESENTS

"THE TRACTOR TRANSMISSION OF TOMORROW"

The IH "Agriomatic" 8-speed transmission which is highlighted in the cut-away section here may at first glance appear to be a complex mass of gears, shafts and levers, etc., but if we build up the principle on which it is based in easy stages from a simple two-speed transmission, it will attain a far different appearance in our eyes. The design is in fact simple, sturdy and exceptionally compact.

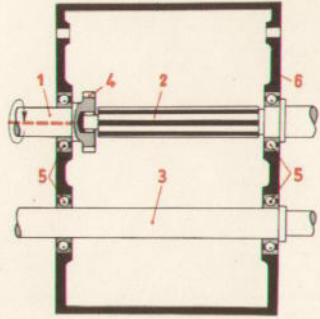

This is a simplified change-speed transmission having only two speeds. There is the case 6 to support the shafts 2 and 3, their bearings 5, and to contain the oil for lubrication.

The drive, as indicated by the broken red line, is transmitted from the engine through the clutch to the driving shaft 1 on which gear 4 is machined. The drive can be connected or disconnected by the clutch. Shaft 2 is splined and is the main shaft. One end of the main shaft is supported in a bearing inside the end of driving shaft 1 but is otherwise in no way connected to it. Shaft 3 is the countershaft; so named because it rotates in the counter direction to the main shaft, i. e. counter-clockwise when viewed from the front end of the tractor.

50

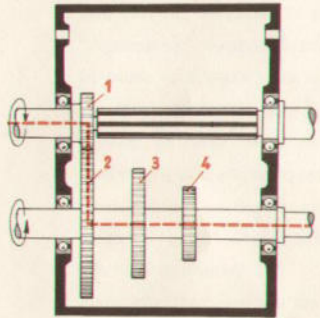

The countershaft carries three gears 2, 3 and 4 which are keyed to it. Gear 2 is in constant mesh with gear 1 on the driving shaft. These are the constant mesh gears. The difference in the number of teeth between individual gears of a pair decides their difference in speed.

The drive from the engine is transmitted down through the constant mesh gears 1 and 2 to the countershaft. The flow of power is indicated by the broken red line.

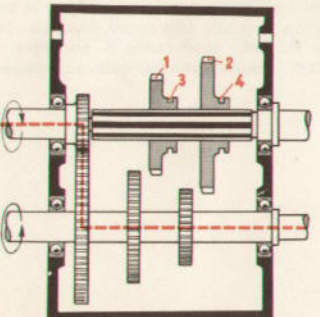

Gears 1 and 2 are a splined fit on the main shaft and free to slide on it. They are provided with collars 3 and 4 to receive the gear shifting forks.

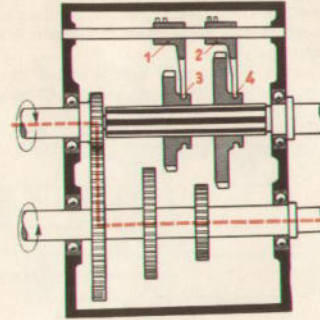

The gears are slid on the shaft by means of the gear-shift lever operating shifter forks 1 and 2 engaged in the collars machined on the sliding gears as at 3 and 4.

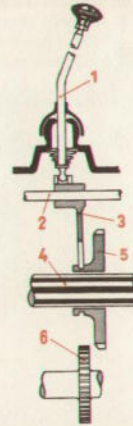

Here you can see the gear-shift lever 1, gear shifter rod 2, shifter fork 3, main shaft 4, with sliding gear 5, and a keyed-on countershaft gear 6.

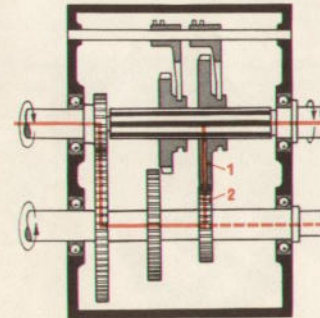

Now if we slide gear 1 into mesh with gear 2 the drive will be taken back up to the main shaft and can pass on rearwards to the final drive, as shown by the full red line. We have thus engaged the first speed.

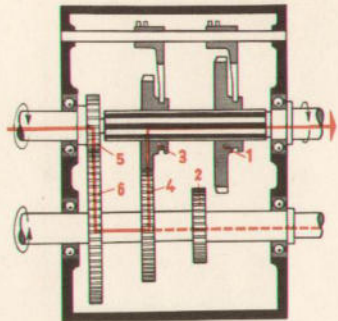

To engage the second speed we must slide the first pair of gears 1 and 2 out of engagement and the second pair 3 and 4 into engagement. Now the drive travels down through the constant-mesh gears 5 and 6 to the countershaft and back up to the main shaft via gears 4 and 3 giving the second speed. Since the ratio of the second gear pair is higher than the ratio of the first gear pair, the main shaft will rotate at a faster speed.

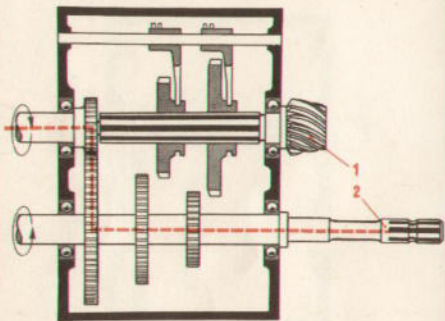

Suppose we now extend the countershaft rearwards and spline the end of it as at 2, we will then have a power take-off shaft with which to drive machines and implements. The broken red line indicates the power path to the p.t.o. Pinion 1 on the main shaft is the spiral bevel pinion for the differential gear.

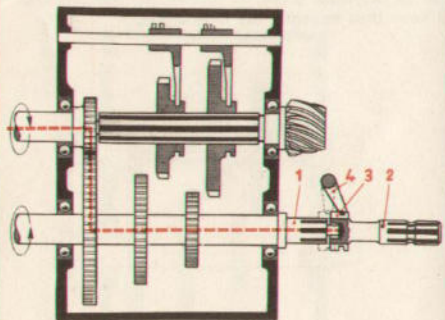

Then let's make the countershaft in two sections 1 and 2 and add a splined sleeve 3 to join them together, we can then disconnect the p.t.o. drive at will by means of a separate lever and shifter fork 4. Note that the broken red line now stops at the splined sleeve. The position to which the splined sleeve is moved when it joins the two sections of the countershaft is indicated by the broken black line.

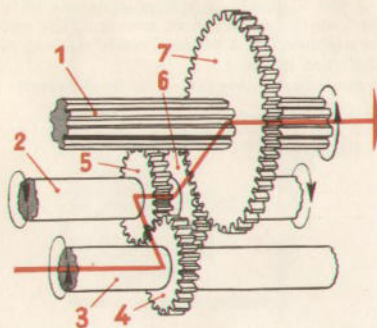

In order to reverse the direction of rotation of the mainshaft for reverse speed the drive is first transmitted from the countershaft 3 across to a reverse idler shaft 2 carrying two gears 5 and 6. The drive passes from gear 5 along the reverse idler shaft to gear 6 and then up to the main shaft gear 7 and rearwards to the final drive, which now rotates in the opposite direction, the flow of power being indicated by the full red line. Note the arrows indicating the direction of rotation of the shafts.



From the foregoing it will be seen that by using longer shafts, carrying more gears, contained in a larger case, we can produce any number of speeds desired within obvious limits.

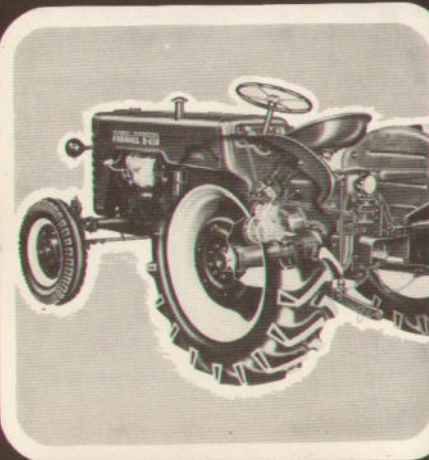

Like the two-speed transmission, the "Agromatic" transmission has a driving shaft and a main shaft to which the sliding gears are splined. The main shaft differs in that it is made up of two sections, as we shall see later. The other main differences are that the "Agromatic" has two countershafts, one fitted inside the other — the outer one, carrying the keyed gears, being free to rotate on the inner one — and a multiple steel disc clutch which connects or separates the two countershafts. They thus rotate together or independently of one another, according to whether the "Agromatic" clutch is engaged or disengaged.

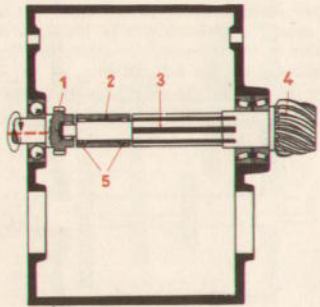

Now let us build up the "Agriomatic" transmission gradually. First, we have the driving shaft with constant mesh pinion 1. Then comes the main shaft which is in two sections 2 and 3. Part 2 is hollow and runs on a needle bearing 5 on the small end of section 3. The end of section 3 is supported in a bearing inside the end of the driving shaft and pinion 1. Pinion 4 is the spiral bevel drive pinion for the differential gear.

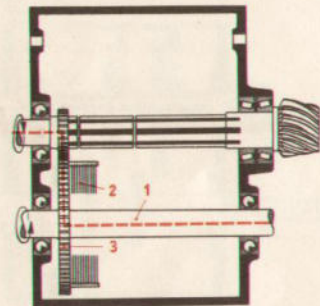

Next we have the inner countershaft 1 to which half the "Agriomatic" clutch, i.e. ten driving plates 2 and constant mesh gear 3, are attached.

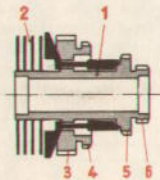

Then comes the outer or hollow countershaft 1 and the other half of the "Agriomatic" clutch, i.e. ten driven plates 2, and the four keyed-on countershaft pinions 3, 4, 5 and 6.

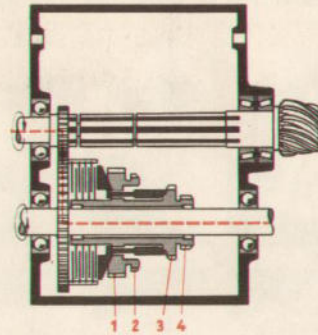

Now let's put the hollow countershaft with the driven plates and gears on the inner countershaft with the driving plates, as in this picture. The power flow to the countershaft is indicated by the broken red line. Note that the clutch is disengaged and power is not transmitted to the hollow countershaft pinions 1, 2, 3 and 4.

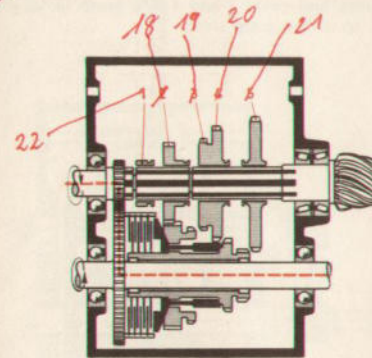

Finally we have the four sliding pinions 2, 3, 4 and 5 on the main shaft and the splined sleeve 1 for joining the main shaft to the driving shaft. Let us now follow the drive as it passes from the engine clutch through the "Agriomatic" transmission and on rearwards. To make this more simple we'll divide the gears into two range groups, low and high, and deal with the four low ones first. In the low range the "Agriomatic" clutch is engaged and in the high range it is disengaged.

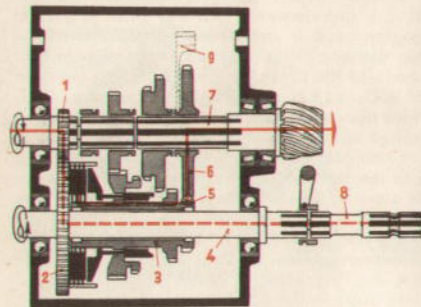

In this diagram you can see how the drive for first speed passes via constant mesh gears 1 and 2 through the "Agriomatic" clutch, along the two countershafts, 3 and 4, rotating together as the "Agriomatic" clutch is engaged, and then back up through gears 5 and 6 to the main shaft 7 and on rearwards. The flow of power is indicated by the full red line and the power flow to the p.t.o. 8 by the broken red line. 9 indicates the gear shifter fork.

To engage second speed we must now slide gears 1 and 2 out of mesh and gears 4 and 3 into mesh. The drive now follows the same route down to the coupled countershafts 5 and 6 but passes back up to the main shaft through gears 3 and 4.

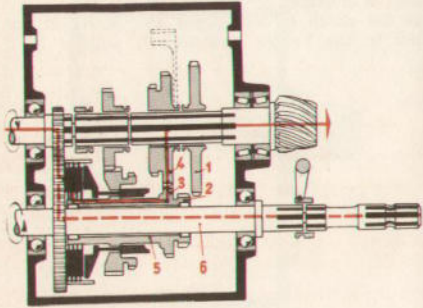

To obtain third speed it is necessary to slide gears 1 and 2 out of mesh and gears 3 and 4 into mesh to take the drive back up to the main shaft.

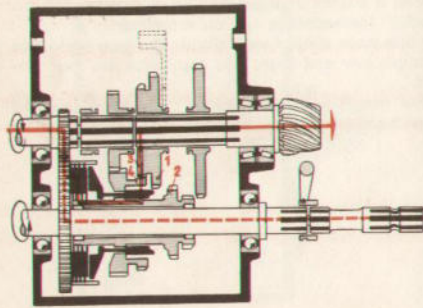

The two gears for fourth speed are 1 and 2 which are always in mesh like constant-mesh gears 3 and 4. They are then, in fact, the constant-mesh gears for the hollow, or outer, second countershaft 5. Note also that the lower gear 2 is approximately twice as wide as gear 1. On disengaging gears 9 and 10 we can therefore slide gear 1 some distance to the rear without disengaging it. Now we come to the break in the main shaft, between parts 7 and 8. Gear 1 has a double duty to perform. First, it must bridge this gap by sliding across it and connecting the two splined sections 7 and 8, otherwise section 7 will rotate on its own, and secondly it must also transmit the power up to the main shaft. The drive still follows the same route down to countershafts 5 and 6 as in the three other speeds but now passes back up to the main shaft via gears 2 and 1, across the gap in the main shaft through gear 1 and on rearwards to the final drive. You will have noticed that the "Agriomatic" clutch remains engaged when shifting gears in the 4 speeds of the low range. All sliding gears are moved by the gear shifting lever.

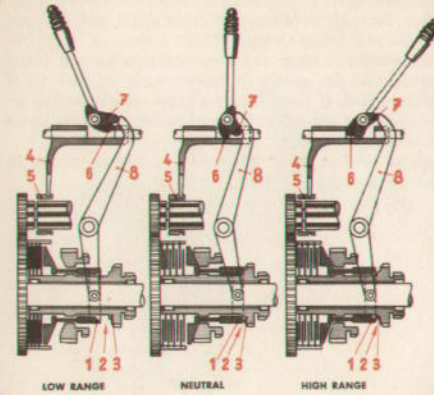
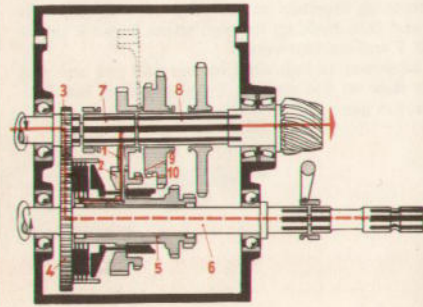

Having now seen how the four low range speeds are obtained, we must see what happens when we move the "Agriomatic" lever.

In the left-hand diagram the lever has been moved forward to the low range position and the "Agriomatic" clutch is engaged. In the middle diagram, the "Agriomatic" lever is shown in the neutral position and the "Agriomatic" clutch is disengaged. In the right hand diagram, the lever is in the high range position and the "Agriomatic" clutch remains disengaged. In the low range and neutral positions the driving shaft is separated from the main shaft; but in the high range the "Agriomatic" shifter fork 4 has moved the splined sleeve 5 across the gap and joined the two shafts together. Note that in neutral the clutch release and brake ring 1 has contacted the countershaft brake cone 3, as can be seen at 2, to bring the hollow countershaft to a standstill to facilitate engaging the sliding gears. In the high range the brake is freed again — note the gap at 2 — and the hollow countershaft is free to rotate. Movement of the "Agriomatic" lever, therefore, actuates only the two cams 6 and 7 which in turn move shifter fork 4 and "Agriomatic" clutch actuating arm (eccenter lever) 8. All gear movements are carried out with the gear shift lever, as already stated.

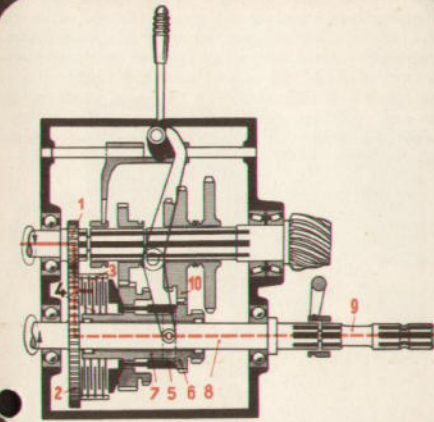

If we now disengage the "Agriomatic" clutch with the "Agriomatic" lever as shown here, the drive will be interrupted. It travels down the first pair of constant-mesh gears 1 and 2 to the driving half of the "Agriomatic" clutch 3, but it can go no further as the two halves of the clutch, 3 and 4, are separated. The tractor will therefore come to a standstill. Partial re-engagement of the "Agriomatic" clutch will gradually set the tractor in motion again. Holding the "Agriomatic" lever in intermediate positions for short periods will give any desired speed, within the range of the speed engaged, due to slipping of the "Agriomatic" clutch halves 3 and 4. You will notice that although in neutral, due to disengagement of the "Agriomatic" clutch, the gear pair 10 and 6 for 2nd gear, low range, has remained engaged. When the "Agriomatic" clutch is disengaged the gears may be shifted with the gear lever without operating the engine clutch. In order to facilitate this, the rear of the "Agriomatic" clutch release ring 5 is cone-shaped and bears against the hollow countershaft brake cone 6, bringing the shaft 7 quickly to a standstill, as we have already seen. Meanwhile the inner countershaft 8 and engaged p.t.o. shaft 9 continue to rotate at a constant speed.

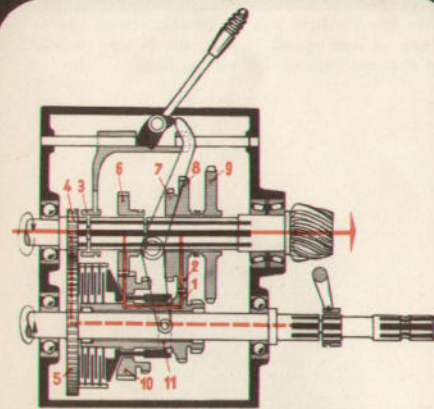

Having disengaged the "Agriomatic" clutch and thus interrupted the drive, we can easily restore it through the second set of constant-mesh gears, 6 and 10, if we couple the driving shaft and the main shaft together. This can be done by moving the "Agriomatic" lever to the rear, which moves the splined sleeve 3 in this picture across the gap between the driving shaft and the main shaft. To do this the engine clutch must be disengaged to bring the driving shaft 4 to a standstill.

The drive will now flow through the second pair of constant-mesh gears, 6 and 10, to the hollow countershaft 11. Since the ratio of this pair of gears is higher than that of the first pair, 4 and 5, the hollow countershaft will rotate faster. By using the engine clutch and gear shifting lever in the conventional manner we can now shift the four sliding gears 6, 7, 8 and 9 again, just as in the low range, and obtain the four high range speeds 5, 6, 7 and 8. The same gear pair, 1 and 2 here, as in the previous picture is still engaged but now serves as 6th gear in the high range. Note the changed downward path of the flow of power indicated by the full red line.

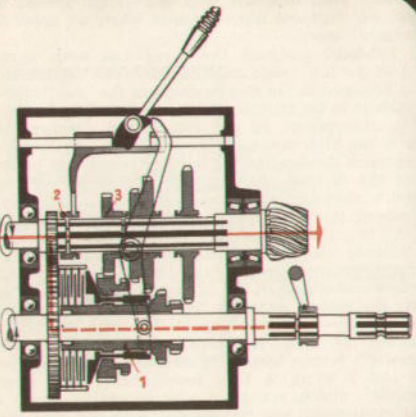

In the eighth speed the drive does not pass down to the hollow countershaft 1. It passes straight along the main shaft since the gap between the main shaft and driving shaft is already bridged by splined sleeve 2, and the sleeve on pinion 3 joins the two sections of the main shaft together as 8th speed is shifted with the gear-shift lever. Meanwhile, if engaged, the p.t.o. shaft rotates at the same constant speed for a given throttle setting as in the 4 low range speeds. The straight-through flow of power in eighth speed is indicated by the full red line.

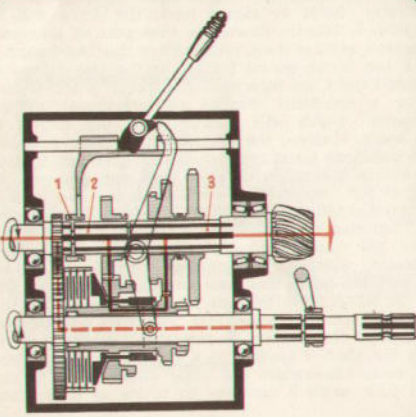

A direct change from a high range speed to the corresponding low range speed may be made without using the engine clutch or gear lever by simply moving the "Agriomatic" lever to the full forward position. This movement first slides the splined sleeve 1 bridging the gap between the driving shaft and the main shaft away from the gap, and then engages the "Agriomatic" clutch. 6th speed, high range, is engaged here. The power flow is indicated by the full red line.

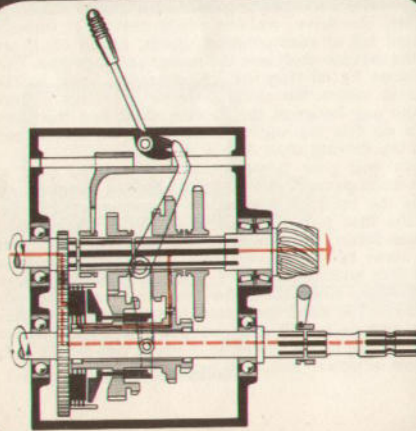

Here the movement has been completed and the power now flows via the first pair of constant-mesh gears. In the picture, second speed, low range, is now engaged. Note the changed path of the full red line.

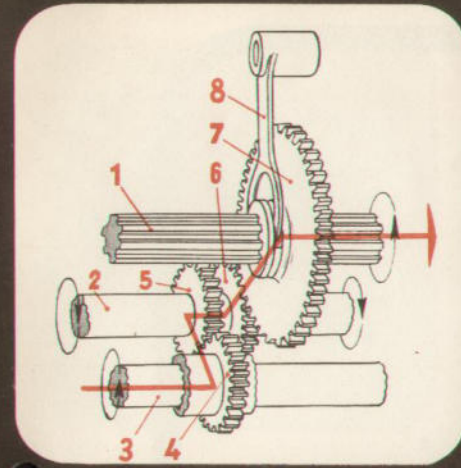

In order to obtain reverse rotation of the main shaft 1 for reverse speed, the drive is first transmitted to a reverse idler shaft 2 on which are mounted two gears, 5 and 6. Gear 4 on the hollow countershaft is in constant mesh with gear 5 of the reverse idler shaft, so that the latter always idles in the reverse direction when the hollow countershaft rotates. It first does useful work when gear 7 on the main shaft is engaged by the gear lever with gear 6 on the reverse idler shaft, and the main shaft is driven in the reverse direction, giving reverse speed. Gear 7 serves both for the 1st and 5th forward speeds and the reverse speeds. Thus two reverse speeds are available, one when the "Agriomatic" clutch is engaged (low range), and another when the "Agriomatic" clutch is disengaged (high range). 8 is the gear shifter fork.

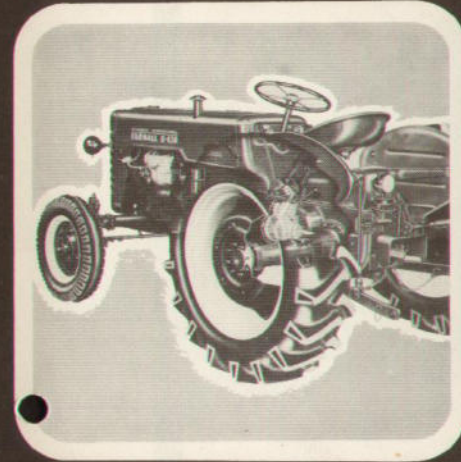

Having now gradually built up the "Agriomatic" 8-speed tractor transmission and seen how the various speeds are obtained, and how the "Agriomatic" clutch and the two countershafts work, let us take a look at a cut-away of the complete "Agriomatic" transmission. The numbers indicate the following principle "Agriomatic" parts, which, for the sake of clarity, were somewhat simplified in the preceding pictures. (Narrator then enumerates the various parts according to the key and adds suitable remarks.)

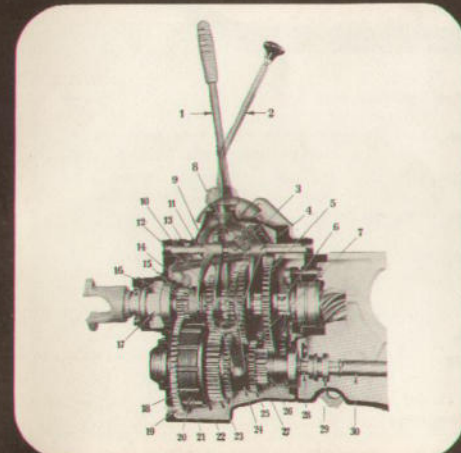

(See key to enlargement overleaf)

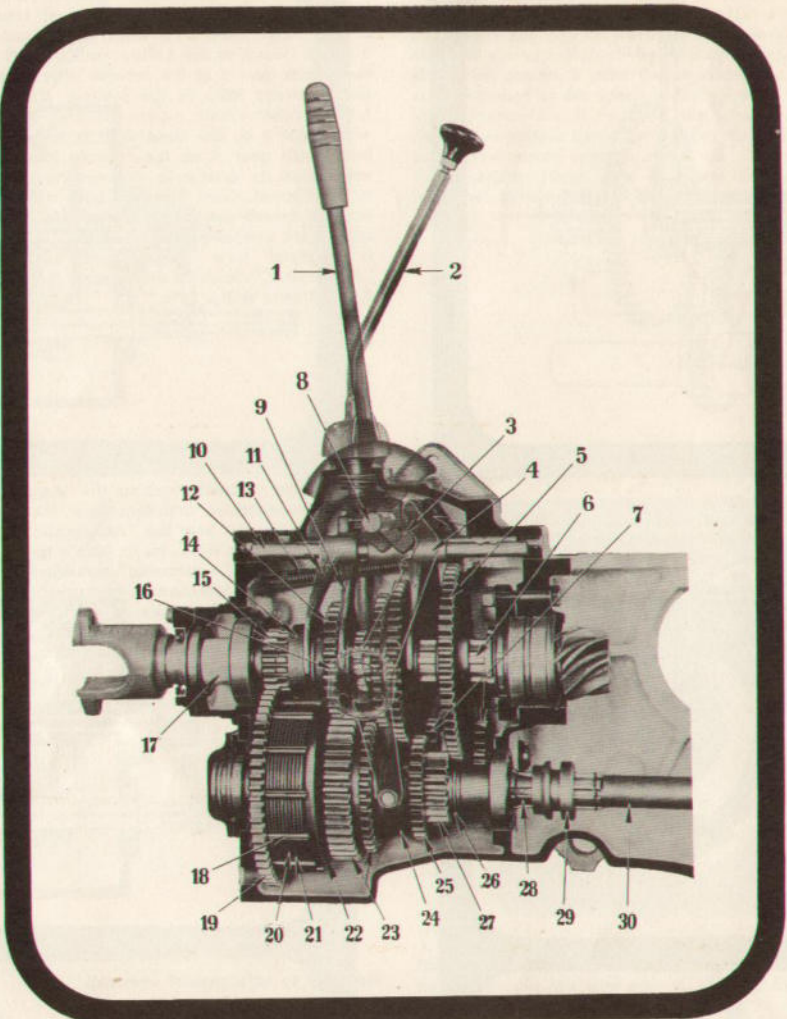

Key to IH "Agrimatic" 8-speed Tractor Transmission.

- | | | |
|----------------------------------------------|--------------------------------------------------------------------|-------------------------------------------------------------|
| 1— "Agrimatic" lever | 13— Hollow countershaft brake spring | 24— Clutch release ring with hollow countershaft brake cone |
| 2— Gear-shift lever | 14— Splined sleeve, high range | 25— Hollow countershaft gear, 2nd, 6th and reverse speeds |
| 3— Actuator cam | 15— Driving shaft pinion | 26— Thrust bearing for hollow countershaft |
| 4— Clutch actuating arm | 16— Eccenter pivot adjusting flange | 27— Hollow countershaft gear, 1st and 5th speeds |
| 5— Sliding gear, 1st, 5th and reverse speeds | 17— Driving shaft with bearing spacer | 28— Countershaft |
| 6— Main shaft | 18— Roll pins | 29— P.T.O. splined sleeve |
| 7— Reverse idler gear | 19— Constant-mesh gear | 30— P.T.O. shaft |
| 8— Shifter shaft | 20— Clutch disc, small, driven | |
| 9— Shifter fork, 4th and 8th speeds | 21— Clutch disc, large, driving | |
| 10— Shifter rod, high range | 22— Pressure plate | |
| 11— Shifter fork, high range | 23— Constant-mesh gear high range and 3rd and 4th low range speeds | |
| 12— Sliding gear, 4th and 8th speeds | | |

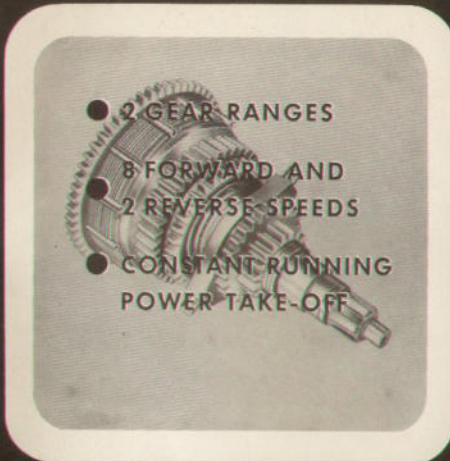

- The "Agrimatic" provides:
- Two gear ranges.
 - 8 forward and two reverse speeds.
 - Constant running power take-off.

- It also makes it possible to:
- Change over from high to low range without declutching or shifting gears.
 - Start or stop the tractor without declutching or shifting gears.
 - Reduce the forward travel or stop the tractor while maintaining constant power take-off speed.

This strip film has dealt with the working principle of the "Agrimatic" 8-speed transmission. Its many advantages to the farmer in the field are dealt with in various publications which are available to all. A study of their contents is well worth while.



Produced by the International Harvester Company m.b.H., Merchandising Services Dept., Neuss, Rhine, Germany.

